

# The CORETEX Group

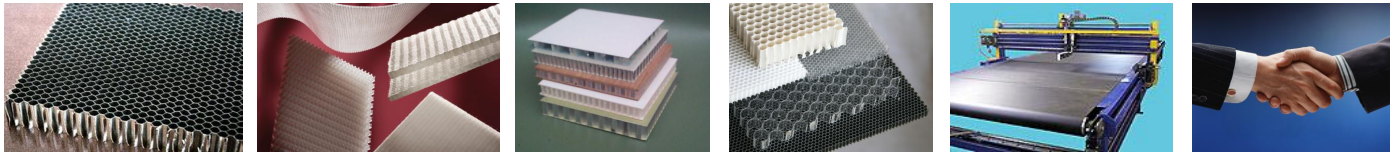

Innovative lightweight honeycomb cores, panels, composites, adhesives, process equipment & consultancy



**Whilst our website is undergoing an update, the following data should guide you on what we can offer**

## About Us

### Our Business Philosophy



The objective of our business is to give you **'value for money'**.

- We can save you time and money through innovative design solutions
- Short cutting development time and getting you to market faster.
- Our company is built on the principles of making quality products and providing reliable service.
- Our diversified product range continues to grow by following trends, improving our standard products, and listening to the customer.

**So, how can we help you?**

### The Owner



Geoff Layland, Managing Director

The Coretex Group is headed by Managing Director, Geoff Layland, and supported by a team of like minded Engineering professionals, dedicated to solving your problems, reducing costs and developing long term and profitable business relationships.

Geoff has spent 30 years in Engineering Design, Production and Sales & Marketing of Honeycomb Cores, Honeycomb and Lightweight Composite Structures and Composite Panel Process Machinery.

If you are looking for a supportive supplier to help you achieve your goals, then give us a call to see what we can offer. In the unlikely event we can't help you - we probably know a man who can!

We look forward to hearing from you.

# The CORETEX Group



Innovative lightweight honeycomb cores, panels, composites, adhesives, process equipment & consultancy

## Our Products:

### CORETEX Honeycomb and Sandwich Panel Solutions

#### Honeycomb Sandwich Panels

- Lightweight & Strong
- Excellent stiffness
- Skins: Aluminium, Steel, GRP, MDF, PVC Plywood, etc
- Cores: Aluminium Honeycomb and Polypropylene PP Honeycomb, Foams,
- Maintenance free options



Polycarbonate (PC) Honeycomb Core

#### Already used in

- Architectural Building Cladding
- Lightweight interior architectural panels
- Aerospace, Marine & Transport Flooring, Walls & Partitions
- Silk Screen Printing Tables
- CNC Vacuum Bases
- Lightweight Floors, Walls, Ceilings, etc
- Special Purpose Panel Design

Get a quote now at [info@CoretexGroup.co.uk](mailto:info@CoretexGroup.co.uk)

### CORETEX High Volume Sandwich Panel Solutions

#### High Volume Sandwich Panel Production

- Latest Advanced Automated Laminating Equipment and Adhesives
- Capacity 1000+ sqm per day
- Repeatable Quality and Fast turnaround
- Typical panel size 3000mm x 1500mm – larger on request
- Skins: Aluminium, Steel, GRP, MDF, OSB, Plywood, PVC, ABS, etc
- Cores: EPS, XPS, PIR, Foams, PP Honeycombs, MDF, Timber, etc

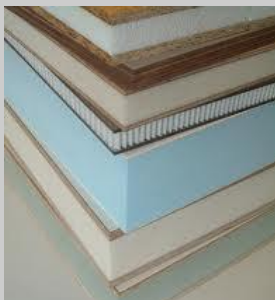

High Volume Panel Manufacturing

#### Benefits

- UK Based Manufacture
- Very competitive pricing
- Repeatable Quality
- Fast turnaround
- Special Purpose Panel Design
- Technical Guidance
- Ideal for SIP Panel Production
- Subcontract - offload production peaks
- Export shipping available

Get a quote now at [info@CoretexGroup.co.uk](mailto:info@CoretexGroup.co.uk)

# The CORETEX Group



Innovative lightweight honeycomb cores, panels, composites, adhesives, process equipment & consultancy

## CORETEX Aluminium Honeycomb Solutions

### Aluminium Honeycomb Core

- Commercial 3003 Grade
- Aerospace 5052 Grade
- Perforated on Non Perforated foil
- Lightweight & Strong
- Lightweight - from 16Kg/M3
- High compression & shear strength
- Cell Diameters 3.1, 6.4, 9.6, 12.7, 19.1, 25.4 (mm):
- Cell Diameters 1/8", 1/4", 3/8", 1/2", 3/4", 1":
- Thickness: 4mm to 300mm
- Standard Sheet Sizes: 1250mm (L) x 2500mm (W) and 1500mm (L) x 3000mm (W)
- Special Sheet Sizes:: upto 1800mm (L) wide x 9000mm (W) long
- Supplied in: HOBE Blocks, unexpanded slices or expanded sheets

### Already used in

- Lightweight Marine Panels
- Lightweight Architectural Panels
- Lightweight Truck Panels
- Lightweight Train Panels
- Honeycomb Energy Absorbers
- Laminar Air Flow units
- RFI/EMC Shielded Vents
- Sacrificial Laser beds and Tables
- Honeycomb Composite Panels



Aluminium Honeycomb Core

Get a quote now at [info@CoretexGroup.co.uk](mailto:info@CoretexGroup.co.uk)

## CORETEX Polypropylene (PP) Honeycomb Solutions

### Polypropylene (PP) Honeycomb

- Excellent stiffness
- Lightweight & Strong
- Thermoformable
- Impact Absorbing
- Wide range of skin options
- Wide range of core options
- Maintenance free options



Polypropylene (PP) Honeycomb Core

### Already used in

- Lightweight interior architectural panels
- Lightweight furniture panels
- Energy Absorbing Panels
- Maintenance Free Marin Panels
- GRP Wet layup structures
- Lightweight Truck Panels
- Lightweight GRP Door Panels
- Lightweight Portable Ramps

Get a quote now at [info@CoretexGroup.co.uk](mailto:info@CoretexGroup.co.uk)

# The CORETEX Group



Innovative lightweight honeycomb cores, panels, composites, adhesives, process equipment & consultancy

## CORETEX Polycarbonate (PC) Honeycomb Solutions

### Polycarbonate PC Honeycomb

- Lightweight & Strong – from 60Kg/M3
- Cell sizes from 2.5mm to 12mm diameter
- Thickness: 2mm to 300mm
- Standard Sheet Size: 1250mm x 2500mm
- Standard colours: Grey, White, Clear
- RAL Colour Options
- Good Corrosion Resistance
- Maintenance free
- Energy Absorbing
- Easy to handle, cut and fabricate

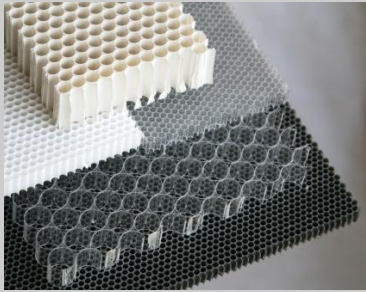

Polycarbonate (PC) Honeycomb Core

### Already used in

- Laminar Air Flow Units
- Refrigerated Display Cabinets
- Energy Absorbers
- Optical Light Collimators
- Laminar Fluid Flow Units
- Lightweight Panels

Get a quote now at [info@CoretexGroup.co.uk](mailto:info@CoretexGroup.co.uk)

## CORETEX Thermoplastic Honeycomb Panel Solutions

### Honeycomb Sandwich Panels

- Lightweight & Strong
- Excellent stiffness
- Thermoformable and weldable
- Recyclable
- Maintenance Free
- Glass fibre and PP Skins
- PP Honeycomb Core
- Bondable and Paintable skins
- Wide range of panel thicknesses and sizes

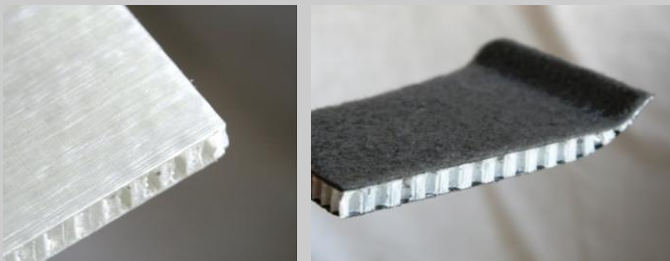

Thermoformable Thermoplastic Sandwich Panels

### Already used in

- Lightweight Truck and Van Panels
- Lightweight Furniture Panels
- Lightweight Stage and Exhibition Panels
- Lightweight Floors, Walls, Ceilings
- Thermoformed Vehicle interiors
- Impact Absorbing Panels
- Lightweight Concrete Shuttering Panels
- Light rigid Watertanks
- Lightweight Monocoque welded units,

Get a quote now at [info@CoretexGroup.co.uk](mailto:info@CoretexGroup.co.uk)

# The CORETEX Group

Innovative lightweight honeycomb cores, panels, composites, adhesives, process equipment & consultancy



## CORETEX Honeycomb Processing Solutions

### Aluminium Honeycomb Saws and Expanders

- Ideal for high volume Honeycomb sheet users (5,000+ M2 per year)
- On site Expander may reduce sheet inventory volume by upto 90%
- On site Expander may reduce damage to pre-expanded sheet inventory
- On site Saw enables faster response for variable sheet thicknesses
- Honeycomb Block (HOBE) and Slices more cost effective



Aluminium Honeycomb Expander

### We can supply

- Honeycomb Block/HOBE Saws
- Aluminium Honeycomb Expanding Machines
- Paper Honeycomb Expanding Machines
- Manual or fully automatic CNC control
- Special design options

**Contact us with your specification!**  
**Get a quote now at [info@CoretexGroup.co.uk](mailto:info@CoretexGroup.co.uk)**



Aluminium Honeycomb HOBE Saw

## CORETEX Panel Bonding Solutions

### Honeycomb & Sandwich Panel Bonding Equipment

- Improve in-house quality
- Reduce bonding cycle times
- Produce larger panels
- Improve profit margins
- Special purpose bonding machinery



Multi day light Hydraulic Press

### We can supply

- Vacuum Presses - single & multi-daylight
- Hydraulic Presses - single & multi-daylight
- Pneumatic Presses
- Belt fed presses
- Nip Roller Presses
- Hot Cure & Cold cure

**Contact us with your specification!**  
**Get a quote now at**

**[info@CoretexGroup.co.uk](mailto:info@CoretexGroup.co.uk)**

# The CORETEX Group

Innovative lightweight honeycomb cores, panels, composites, adhesives, process equipment & consultancy



## CORETEX Adhesive Solutions

### Honeycomb Core and Sandwich Panel Adhesive Systems

- Adhesives specifically designed to bond Honeycomb Cores
- Cold cure or Heat cure
- Variable open times from 4 minutes to 4 hours
- Exceptionally high peel strength
- Very cost effective
- Solvent free



Adhesive Systems

### We can supply

- 2 Part Structural Epoxies
- 2 Part Solvent Free Structural PU
- Eco Friendly Solvent Free Flushing and Purging Systems

**Contact us with your specification!**

**Get a quote now at [info@CoretexGroup.co.uk](mailto:info@CoretexGroup.co.uk)**

## CORETEX Adhesive Application Solutions

### Adhesive Application Systems

- High Volume Automatic PLC / CNC controlled
- Spray heads and accurate metering equipment
- Bead coaters and Roll coaters
- Spray booths
- Purpose built systems



Hi speed adhesive application machinery

### We can supply

- 2 Part Structural Epoxies
- 2 Part Solvent Free Structural PU
- Eco Friendly Solvent Free Flushing and Purging Systems

**Contact us with your specification!**

**Get a quote now at [info@CoretexGroup.co.uk](mailto:info@CoretexGroup.co.uk)**

# The CORETEX Group



Innovative lightweight honeycomb cores, panels, composites, adhesives, process equipment & consultancy

## CORETEX Energy Absorber Solutions

### Honeycomb Energy Absorbers

- Aluminium Honeycomb
- PP Plastic Honeycomb
- PC Plastic Honeycomb
- Lightweight & Compact
- Upto 75% crush volume
- Uniform crush rate
- Maintenance free



Aluminium Honeycomb Energy Absorbers

### Already used in

- Vehicle Impact Barriers
- Thermo formable Body Protection
- Head Impact protection
- Lightweight Body Armour
- Train buffers/overiders
- Elevator/Lift protection
- Purpose Designed Absorption units

Get a quote now at [info@CoretexGroup.co.uk](mailto:info@CoretexGroup.co.uk)

## CORETEX Laminar Air Flow Solutions

### Honeycomb Laminar Air Flow units

- Up to 98% open area
- Minimum pressure loss
- Reduced noise
- Compact design
- Maintenance free options
- For use in air or fluids

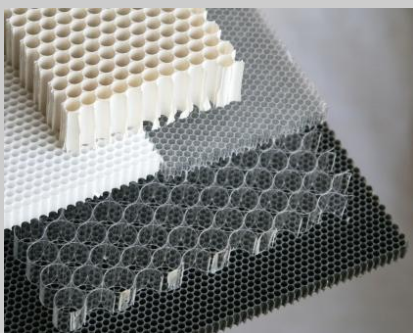

Honeycomb Laminar Air Flow Units

### Already used in

- Wind Tunnels - large and small
- Laminar Air Flow Booths
- Refrigeration Cabinet Air flow
- Air flow measurement devices
- Air curtains/showers
- Directional cooling devices

**Any thickness, any size, any quantity!**

Get a quote now at [info@CoretexGroup.co.uk](mailto:info@CoretexGroup.co.uk)

# The CORETEX Group

Innovative lightweight honeycomb cores, panels, composites, adhesives, process equipment & consultancy



## CORETEX Cleanroom Ceiling Systems

### Cleanroom Ceiling Systems

- Long span (6000mm) walk on ceilings
- Infill panels
- Walk on panels
- Honeycomb Panels
- UK Manufactured
- RAL9010 White or any other RAL

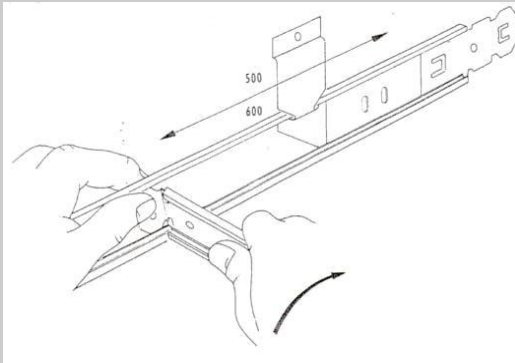

**Fast and Easy Installation**

### We can support

- Class 100,000 to Class 1
- New build or refurbishment
- Pharmaceutical, Biotech, Microelectronics
- Composite Repair, Aerospace & Satellite Build
- Packaging Areas

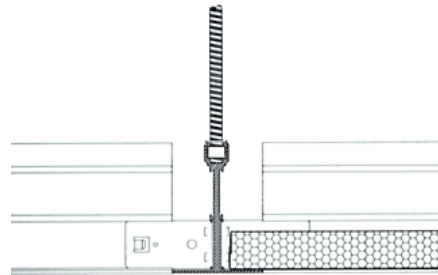

### New T50 and T60 'Walk On' Cleanroom Ceiling System

Contact us with your specification!  
Get a quote now at [info@CoretexGroup.co.uk](mailto:info@CoretexGroup.co.uk)

## CORETEX Consultancy and Design Services:

### Product Design Consultancy

We offer a cost effective **Design Consultancy** on a wide range of **Honeycomb and Composite Panel** related projects.

Being involved at an early design stage can be very productive as it can give direction and focus and may reduce costly changes further down the development cycle.

If you already have a design in production we may be able to improve the product through design change suggestions, process machinery improvements or cost effective sub contracting.

**Our fees are very cost effective** – please call to discuss your project on +44 (0)871 918 1525 or email us at [info@CoretexGroup.co.uk](mailto:info@CoretexGroup.co.uk)

### Product Sales Agency & Manufacturing Representation

We are always looking for innovative and cost effective products and composite raw materials to add to our portfolio.

If you need professional representation in the UK then contact us to see if we can help.

Telephone us on +44 (0)871 918 1525 or email us at [info@CoretexGroup.co.uk](mailto:info@CoretexGroup.co.uk)



# The CORETEX Group

Innovative lightweight honeycomb cores, panels, composites, adhesives, process equipment & consultancy



## Contact Us:

**At Coretex we do things a little differently.**



*(Any resemblance to the owner is merely coincidental)*

Thinking 'out of the box' is what we do everyday.

So if you are looking for a unique material or innovative solution to your design problem - give us call and see what we can do for you.

You might be pleasantly surprised!

## Our Contact Data



Geoff Layland  
Managing Director

The Coretex Group  
PO Box 2  
Cheltenham  
GL54 5YR  
United Kingdom

[info@CoretexGroup.co.uk](mailto:info@CoretexGroup.co.uk)

Office: +44 (0)871 918 1525  
Fax: +44 (0)871 918 1525  
Mobile: +44 (0)7860 824291